

MINIMUM THRUST AREA (A x B) IN m<sup>2</sup> FOR 1200 kPa TEST PRESSURE

SAFE BEARING LOAD	90° & ø60 BENDS				45° & 30° BENDS				22½° BENDS				11¼° BENDS				DEAD ENDS/TEES				
	25 kPa	50 kPa	75 kPa	100 kPa	25 kPa	50 kPa	75 kPa	100 kPa	25 kPa	50 kPa	75 kPa	100 kPa	25 kPa	50 kPa	75 kPa	100 kPa	25 kPa	50 kPa	75 kPa	100 kPa	
DIA. OF BRANCH OR TEE BRANCH	100	0.82	0.41	0.27	0.20	0.44	0.21	0.14	0.11	0.24	0.12	0.08	N	0.10	N	N	N	0.58	0.29	0.19	0.15
	150	1.68	0.84	0.56	0.42	0.91	0.46	0.30	0.23	0.48	0.24	0.16	0.12	0.24	0.12	0.08	N	1.20	0.60	0.40	0.30
	225	2.55	1.27	0.85	0.64	1.92	0.96	0.64	0.48	1.00	0.50	0.34	0.25	0.48	0.24	0.16	0.12	2.54	1.27	0.85	0.64

N - DENOTES NOMINAL THRUST AREA. REFER TO NOTE 10.

**NOTES**

1. CONCRETE FOR THRUST BLOCKS TO BE N32 MIN. IN ACCORDANCE WITH AS3179 & AS3600 & SHALL BE POURED AGAINST UNDISTURBED SOIL.
2. TAPERS TO HAVE A MIN. THRUST AREA FOR ANCHORS EQUAL TO THE DIFFERENCE IN CORRESPONDING THRUST AREA FOR DEAD ENDS OF EACH DIAMETER OF TAPER.
3. FOR VERTICAL BENDS IN SAG, THE SAFE BEARING LOADS OF THE VARIOUS SOILS MAY BE TAKEN AS TWICE THOSE FOR HORIZONTAL THRUST.
4. UNLESS NOTED OTHERWISE THRUST BLOCKS ARE REQUIRED FOR ALL VALVES ø200 & GREATER & SHALL HAVE A THRUST AREA EQUAL TO THAT FOR A DEAD END. ALSO WHEN IN SOFT CLAY ALL VALVES SHALL HAVE THRUST BLOCKS EQUAL TO THAT FOR A DEAD END.
5. HOLD DOWN BOLTS TO BE M12 STAINLESS STEEL. MIN. EMBEDMENT LENGTH 300mm WITH 75 HOOK, COG OF 50 x 50 x 6 WASHER, STRAPS 40 50 x 6 STAINLESS STEEL PLATE BENT TO SUIT.
6. THRUST BLOCK FOR MATERIALS WITH SAFE BEARING LOAD < 25kPa ARE TO BE DETAILED WITH ENGINEERING DESIGN.
7. FOR PIPES > 225mm DIA. THE THRUST BLOCKS SHALL BE SPECIFICALLY DESIGNED & DETAILED AFTER SOIL TESTING..
8. ALL FITTINGS SHALL BE PROVIDED WITH THRUST BLOCKS FORMED AGAINST SOLID GROUND TO TRANSFER UNBALANCED FORCES FROM FITTING TO SOLID GROUND.
9. NOMINAL THRUST AREA 'N' SHALL BE EFFECTED BY N32 CONCRETE OVER FULL LENGTH OF FITTING, & EXTENDING IN DEPTH FROM THE BOTTOM OF THE TRENCH TO AT LEAST 75mm ABOVE THE TOP OF THE FITTING.
10. TABULATED 'MIN. THRUST AREA FOR ANCHORAGE' APPLY FOR TEST PRESSURE OF 1200kPa. AREAS SHALL BE ADJUSTED PRORATA FOR OTHER TEST PRESSURES EXCEPT THAT NOMINAL THRUST AREAS 'N' SHALL HAVE TO BE CALCULATED FOR TEST PRESSURES OVER 1200kPa.
11. SHAPE & DIMENSIONS OF CONCRETE BLOCKS SHOWN ARE MINIMUM REQUIREMENTS.
12. WHEN PLACING THE CONCRETE ON A PVC PIPE, CARE SHALL BE TAKEN TO AVOID ENCASING THE PIPE COMPLETELY. THE MAXIMUM ENCASEMENT SHALL BE 180°.
13. WHEN PLACING A PVC PIPE IN CONCRETE A MEMBRANE OF POLYTHENE, PVC OR FELT SHALL SURROUND THE PIPE & FITTING TO PERMIT PIPE MOVEMENT IN THE CONCRETE.
14. MINIMUM COVER TO PIPE SHALL BE 600mm REFER TO S2016 FOR MIN. COVER TO INDIVIDUAL PIPE TYPES.

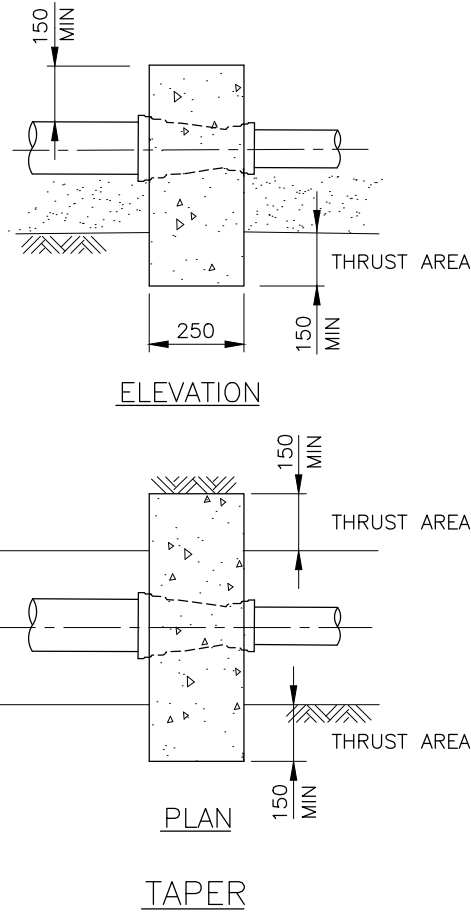

CONCRETE VOLUMES TO COUNTER THRUST (m<sup>3</sup> PER 1200kPa TEST PRESSURE)

DIA	90°	45°	22½°	11¼°
100	0.85	0.45	0.25	0.10
150	1.75	0.95	0.50	0.25
225	3.75	2.00	1.05	0.50

VERTICAL BENDS, CREST

SAFE BEARING LOADS (kPa)

MATERIAL	SAFE BEARING LOAD (kPa)
SOFT CLAY	Requires soil testing to determine safe bearing load
MARINE CLAY	Requires soil testing to determine safe bearing load
MEDIUM CLAY, SANDY LOAM	50
SAND & GRAVEL, HARD CLAY	75
SAND & GRAVEL CEMENTED WITH CLAY	100
SHALE	240

FOR HORIZONTAL THRUST BLOCKS IN TRENCHES WHERE THE COVER TO PIPE IS > 450MM

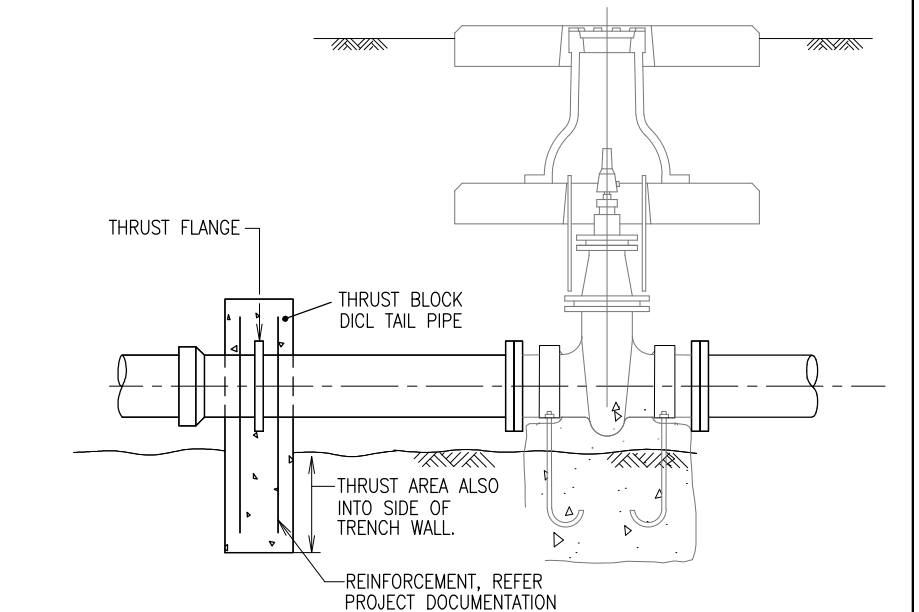
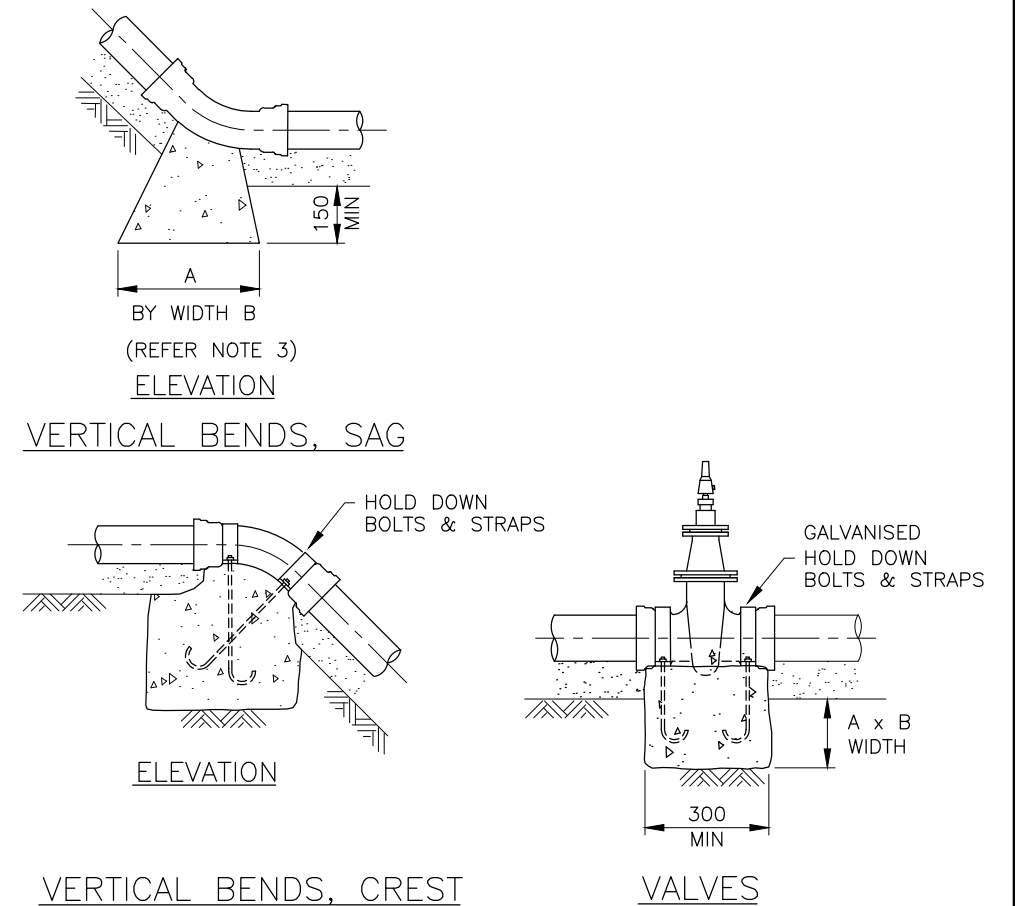

SLUICE VALVE (ø200 & GREATER - SOFT CLAY)

(REFER NOTE 4)

REVISIONS	DATE
D MINOR AMENDMENTS TO NOTES	05/12/23
C DRAWING REINSTATED	27/08/20
B NOTE 1 AMENDED	01/02/07
A ORIGINAL ISSUE	12/03/04

**DISCLAIMER**  
The authors and sponsoring organisations shall have no liability or responsibility to the user or any other person or entity with respect to any liability, loss or damage caused or alleged to be caused, directly or indirectly, by the adoption and use of these Standard Drawings including, but not limited to, any interruption of service, loss of business or anticipatory profits, or consequential damages resulting from the use of these Standard Drawings. Persons must not rely on these Standard Drawings as the equivalent of, or a substitute for, project-specific design and assessment by an appropriately qualified professional.



**THRUST BLOCK DETAILS**  
PIPE DIA ≤ 225

Standard Drawing  
**S2015**

A	B	C	D
---	---	---	---