

For dimension S refer Standard Drawing No. S1046

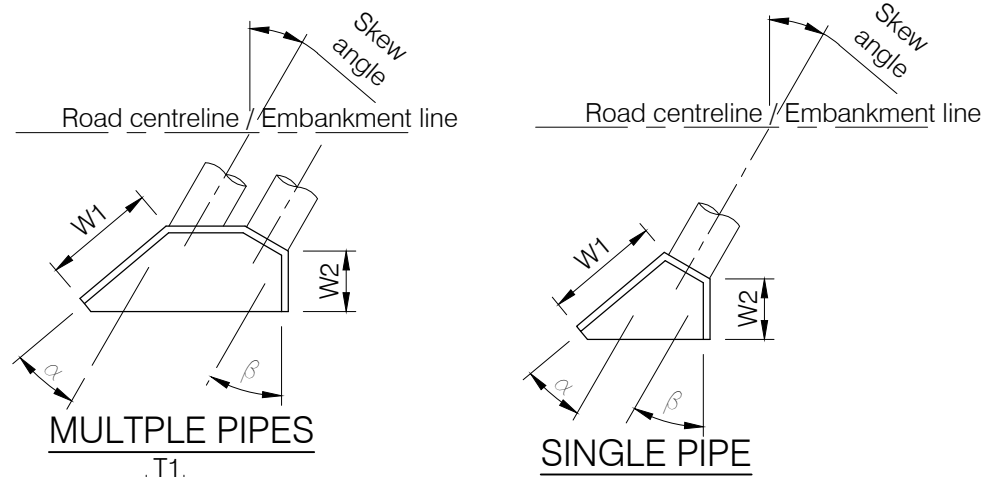

WINGWALL ANGLES

Skew Angle	Wingwall angle	
	α	β
0 - 10	30	30
11 - 20	25	30
21 - 30	20	30
31 - 45	15	30

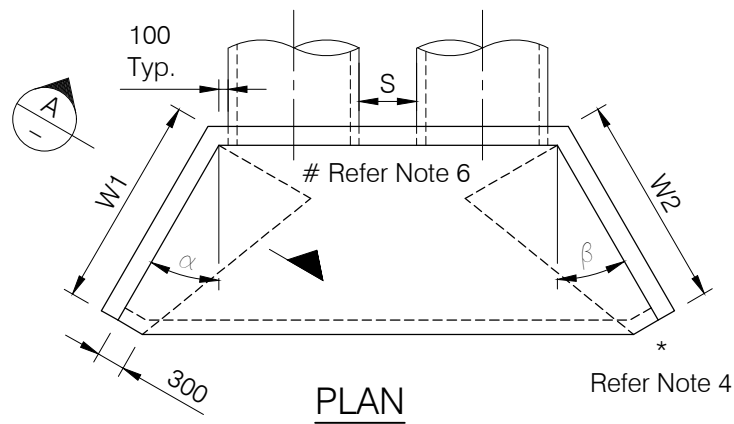
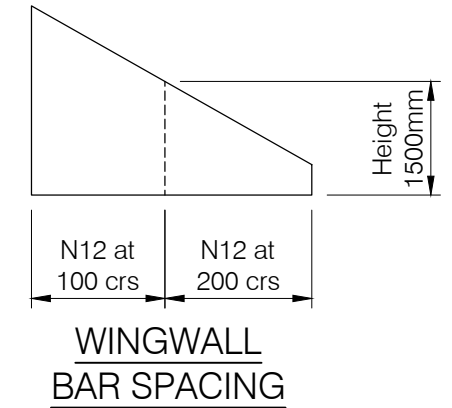

W1 (Angle α) is the wingwall nearer to road centreline / embankment line

TABLE OF DIMENSIONS & REINFORCEMENT

Dia	T1	T2	A	B	M1	M2	M3
375	200	150	450	300	SL82	SL62	-
450	200	150	450	300	SL82	SL62	-
525	200	150	450	300	SL82	SL62	-
675	200	150	450	300	SL82	SL62	-
750	200	200	550	200	RL818	SL62	-
825	200	200	550	200	RL818	SL62	-
900	200	200	550	200	RL818	SL62	-
1050	200	200	550	200	RL818	SL62	-
1200	200	200	550	200	RL818	SL62	-
1350	250	250	600	200	RL1018	SL62	-
1500	250	250	600	#	RL1018	SL62	-
1650	250	250	600	#	RL1018	SL62	-
1800	300	300	650	#	RL1018	SL82	SL82
1950	300	300	650	#	RL1018	SL82	SL82
2100	300	300	650	#	RL1018	SL82	SL82

Refer wingwall bar spacing detail shown above

NOTES

- Concrete shall be grade N32 in accordance with AS 1379 and AS 3600. Minimum cover to be 50mm.
- In areas where the invert is below HAT level, all concrete shall be grade N40. Wall and apron thickness (T1 & T2) to be increased by 30mm. Minimum cover to be 65mm.
- For wingwall lengths (W1 & W2) and skew angle refer to project drawings.
- Stone pitching to be provided to the ends of wingwalls, extending to toe of batter, wherever batter slope exceeds 1 in 4.
- Where height of headwall above the pipe is greater than 300mm, the headwall shall be designed and detailed on the project drawings.
- Headwall reinforcing to be similar to the highest section of the wingwall.
- All dimensions in millimetres.
- Pre-cast units in accordance with these requirements are acceptable.

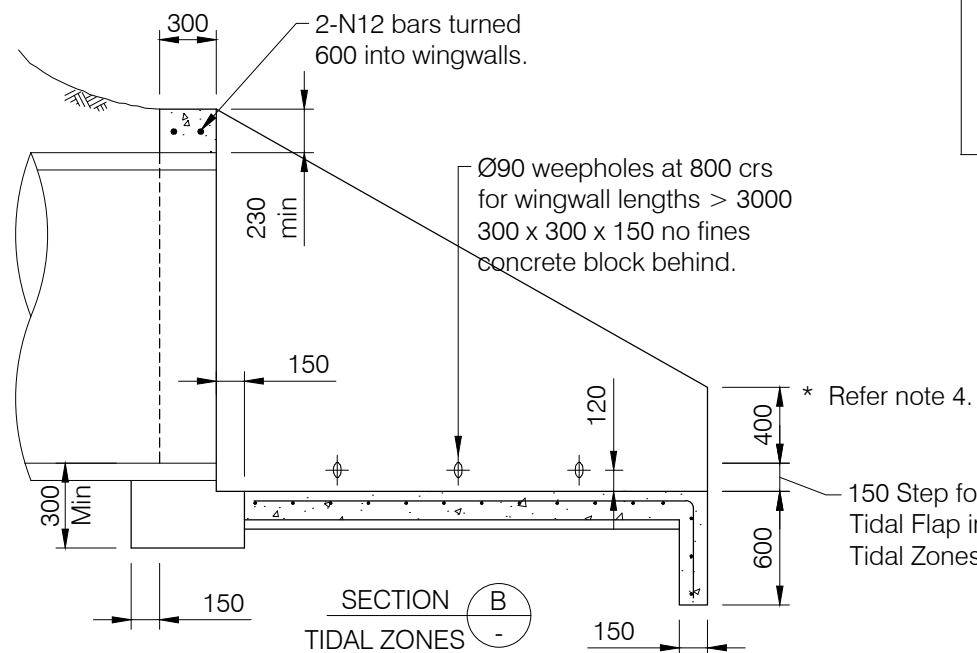
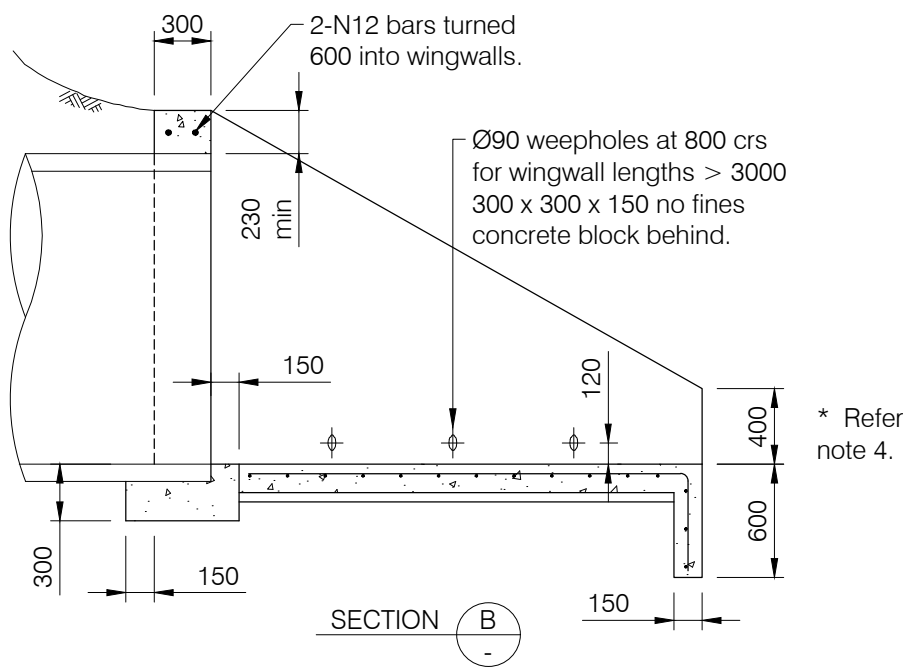
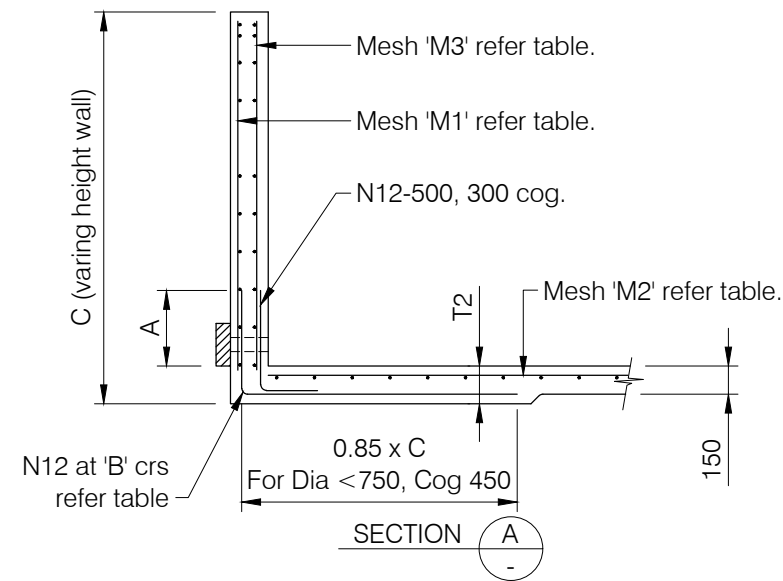
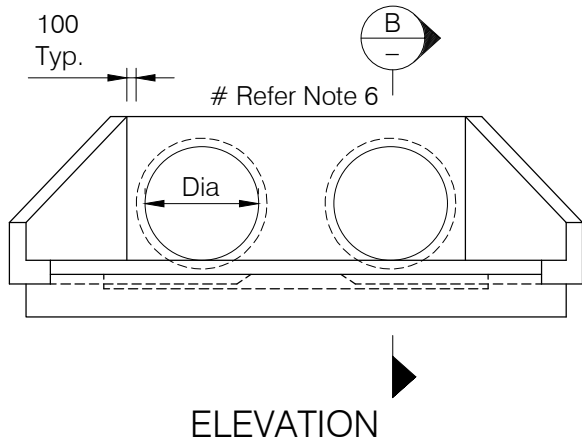

* Refer note 4.

* Refer note 4.
150 Step for Tidal Flap in Tidal Zones

REVISIONS	DATE
D MINOR AMENDMENT TO NOTES	05/12/23
C NOTE ADDED	27/08/20
B TIDAL FLAP STEP ADDED	OCT 11
A ORIGINAL ISSUE	12/03/04

DISCLAIMER
The authors and sponsoring organisations shall have no liability or responsibility to the user or any other person or entity with respect to any liability, loss or damage caused or alleged to be caused, directly or indirectly, by the adoption and use of these Standard Drawings including, but not limited to, any interruption of service, loss of business or anticipatory profits, or consequential damages resulting from the use of these Standard Drawings. Persons must not rely on these Standard Drawings as the equivalent of, or a substitute for, project-specific design and assessment by an appropriately qualified professional.



CONCRETE PIPE HEADWALL WINGWALLS AND APRON

Standard Drawing
S1085

A	B	C	D
---	---	---	---