

**BARRIER KERB AND CHANNEL**

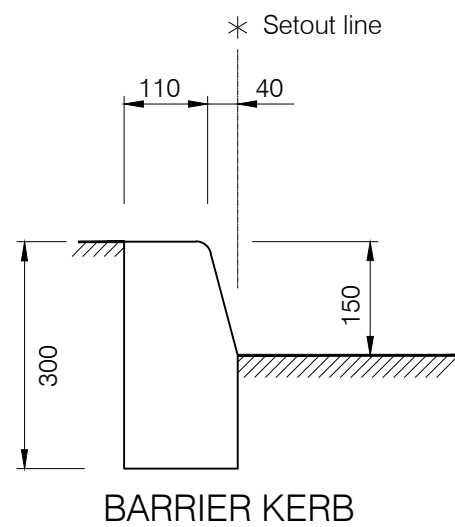

**BARRIER KERB**

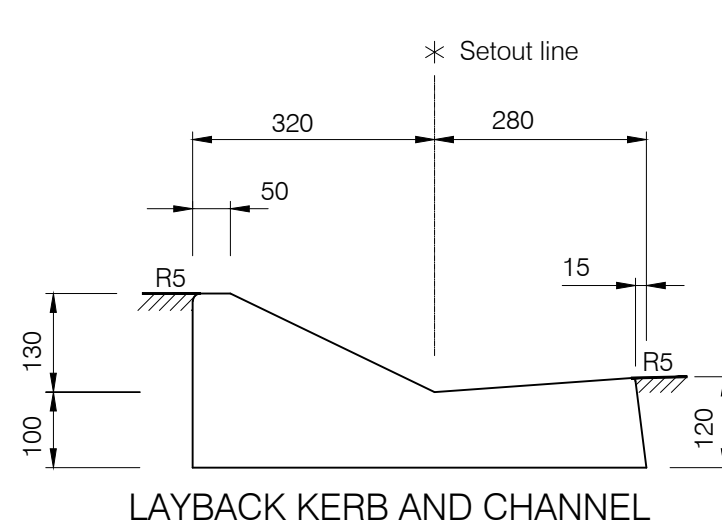

**LAYBACK KERB AND CHANNEL**

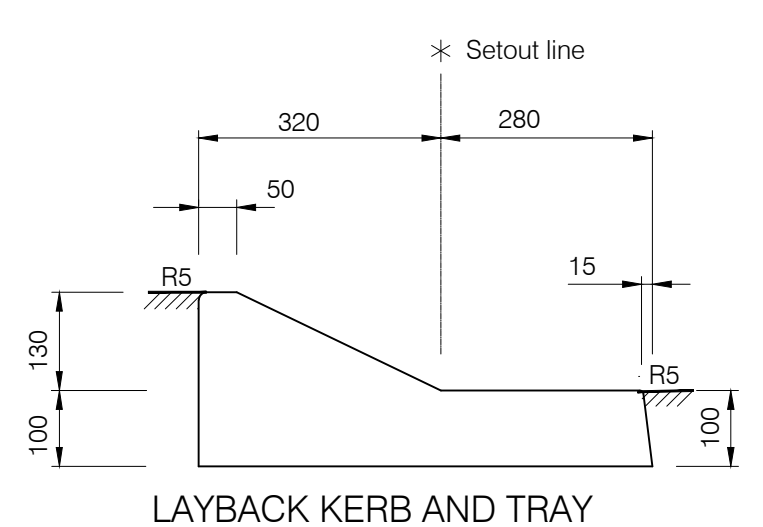

**LAYBACK KERB AND TRAY**

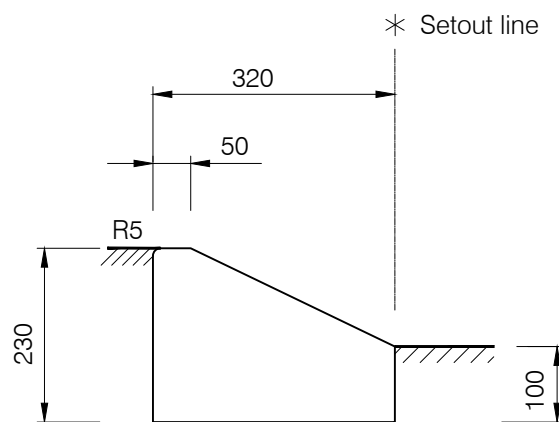

**LAYBACK KERB**

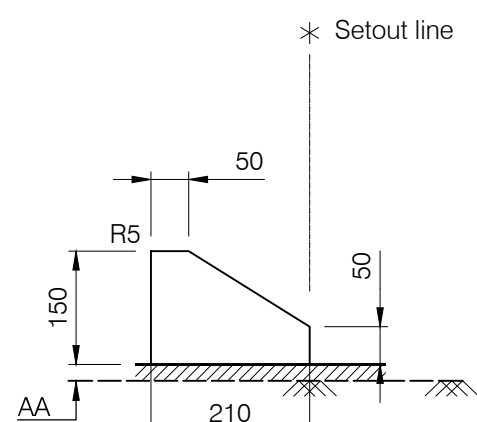

**TYPE 1 (DEPTH 150)  
TYPE 1A (DEPTH 150 + 'AA')**

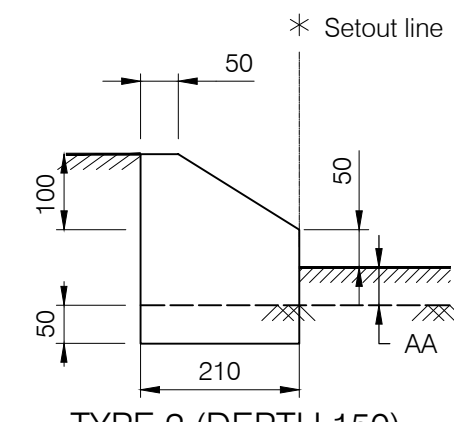

**TYPE 2 (DEPTH 150)  
TYPE 2A (DEPTH 150 + 'AA')  
SEMI-MOUNTABLE KERB**

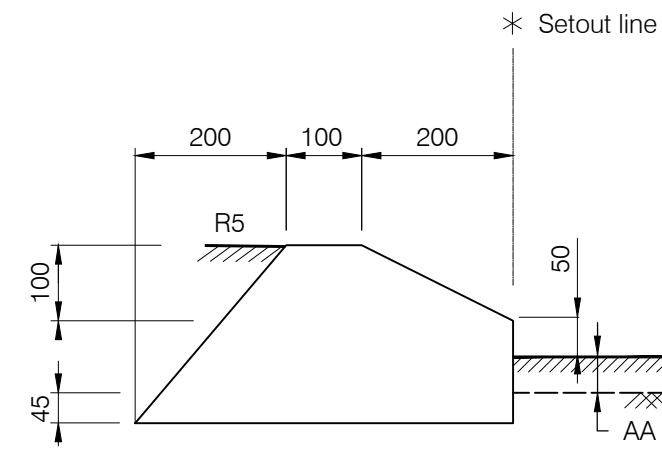

**TYPE 3 (DEPTH 150)  
TYPE 3A (DEPTH 150 + 'AA')**

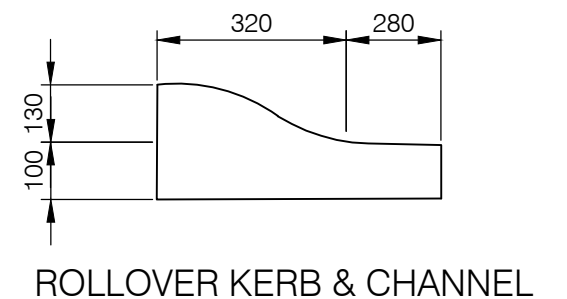

**ROLLOVER KERB & CHANNEL**

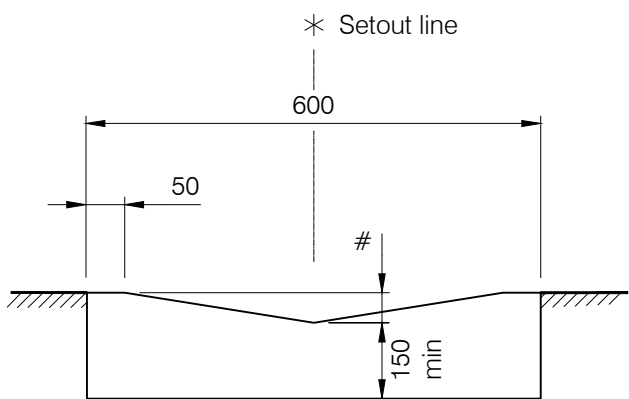

**CONCRETE INVERT**

Type 1 # = 20mm  
Type 2 # = 40mm  
Type 3 # = 75mm

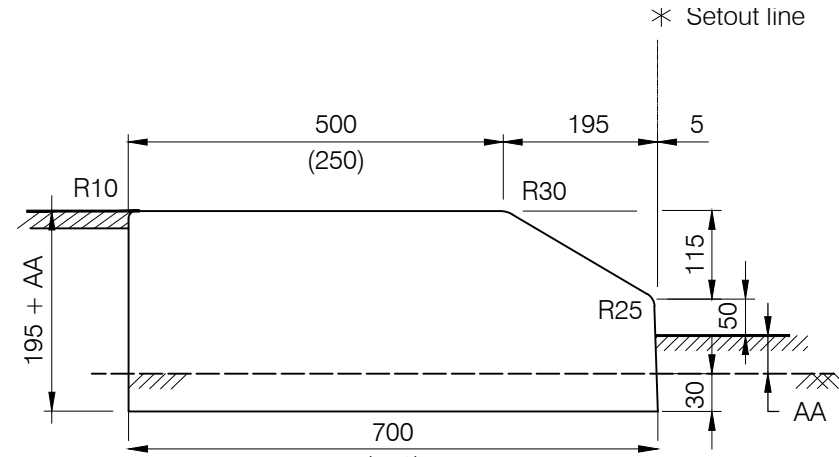

**TYPE 4 (DEPTH 150)  
TYPE 4A (DEPTH 150 + 'AA')  
MAINTENANCE STRIP KERB**

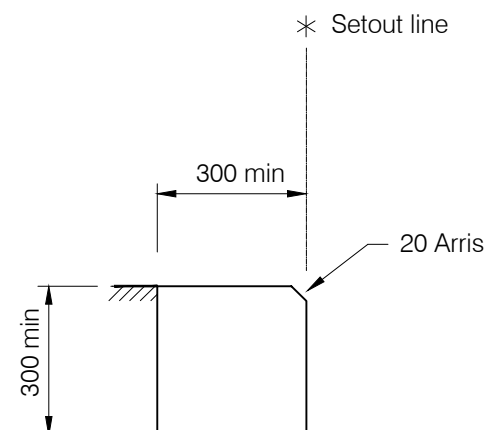

**EDGE RESTRAINT**

**NOTES:**

1. Concrete N32 min in accordance with AS1379 and AS3600.
2. All dimensions are in millimetres.
3. all water capture/directing profiles shall be on grade.
4. Batching documentation to be provided on request.
5. Saw cut or trowel joints at maximum 4m ctrs.
6. AA = Asphalt Allowance, provides for initial asphalt layer and/or future overlay. AA may include the thickness of any combination of: - asphalt corrector course, initial asphalt layers, estimated future asphalt overlay
7. Vehicle access cross overs are to be installed in accordance with S1015

REVISIONS	DATE
H NOTES AMENDED	05/12/23
G MINOR AMENDMENTS	27/08/20
F VARIOUS AMENDMENTS	23/10/17
E FGF BARRIER FLUSH KERB ADDED	26/11/14

**DISCLAIMER**  
The authors and sponsoring organisations shall have no liability or responsibility to the user or any other person or entity with respect to any liability, loss or damage caused or alleged to be caused, directly or indirectly, by the adoption and use of these Standard Drawings including, but not limited to, any interruption of service, loss of business or anticipatory profits, or consequential damages resulting from the use of these Standard Drawings. Persons must not rely on these Standard Drawings as the equivalent of, or a substitute for, project-specific design and assessment by an appropriately qualified professional.



**CONCRETE KERB & CHANNEL  
PROFILES & DIMENSIONS**

Standard  
Drawing

**S1000**

E	F	G	H
---	---	---	---